



Water purification

Thermo Scientific Aquanex Ultrapure Water Purification System

Effortless purity redefined

Canadawide
SCIENTIFIC

thermo scientific

Aquanex Ultrapure Water Purification System

Sets the standard for ease of use and intelligent operation

Count on the Thermo Scientific™ Aquanex™ Ultrapure Water Purification System for convenience, flexibility and reliable water purity. Spend more time on your research and less time figuring out complicated equipment.

Designed with ease of use in mind

- Simple setup: Quick-connect fixtures make installation easy
- Two user interfaces: Works alone or with the Thermo Scientific™ Aquanex™ Touch Smart Dispenser
- Flexibility: Dispense from the unit stand or remove the pipette-style dispenser to fill larger containers
- Change components with ease: Remove the magnetic front panel for quick access—no screws or complicated fixtures; unit automatically recognizes new cartridges

Reliable water quality at your fingertips

- Secure log-in feature
- Seamless event logging, monitoring and reporting
- High-flow smart dispensing
- Volumetric and manual dispensing capability
- Innovative cartridge design for <3ppb TOC
- Heavy duty ultrafilter and 0.1 micron-POU final filter
- Automatic Leak Detection and system shutoff

Supports sustainability

- Water Saver Mode can help you save water when using high-quality feed water
- Responsibly packaged for less waste

Aquanex Touch Smart Dispenser

Dispense Type I water with confidence

Intelligent, ergonomic dispensing in the palm of your hand

- Easy-to-handle pipette-style dispenser
- Sturdy weighted base securely supports the dispenser
- Operate at a range of heights while supported by the base
- Handle is magnetically held on the stand

Flexibility to dispense water where you need it most

- Remove from the stand to fill large containers
- Stand can be set on the bench or wall mounted
- Dispenser can be used up to 10 feet away from the Aquanex main unit
- Two dispensers can be used with the Aquanex system (including optional Type II water dispenser, part number 50138221)

Intuitive, touchscreen display allows for easy operation

- Easily set up and dispense through the dispenser or main unit display
- Quick view of key parameters such as water quality, tank level and dispensing options
- Operate the unit directly from the dispenser, including volume selection
- Volumetric or manual dispensing with the touch of a button
- Volumetric dispensing accuracy is $\pm 2\%$ at volumes ≥ 100 mL

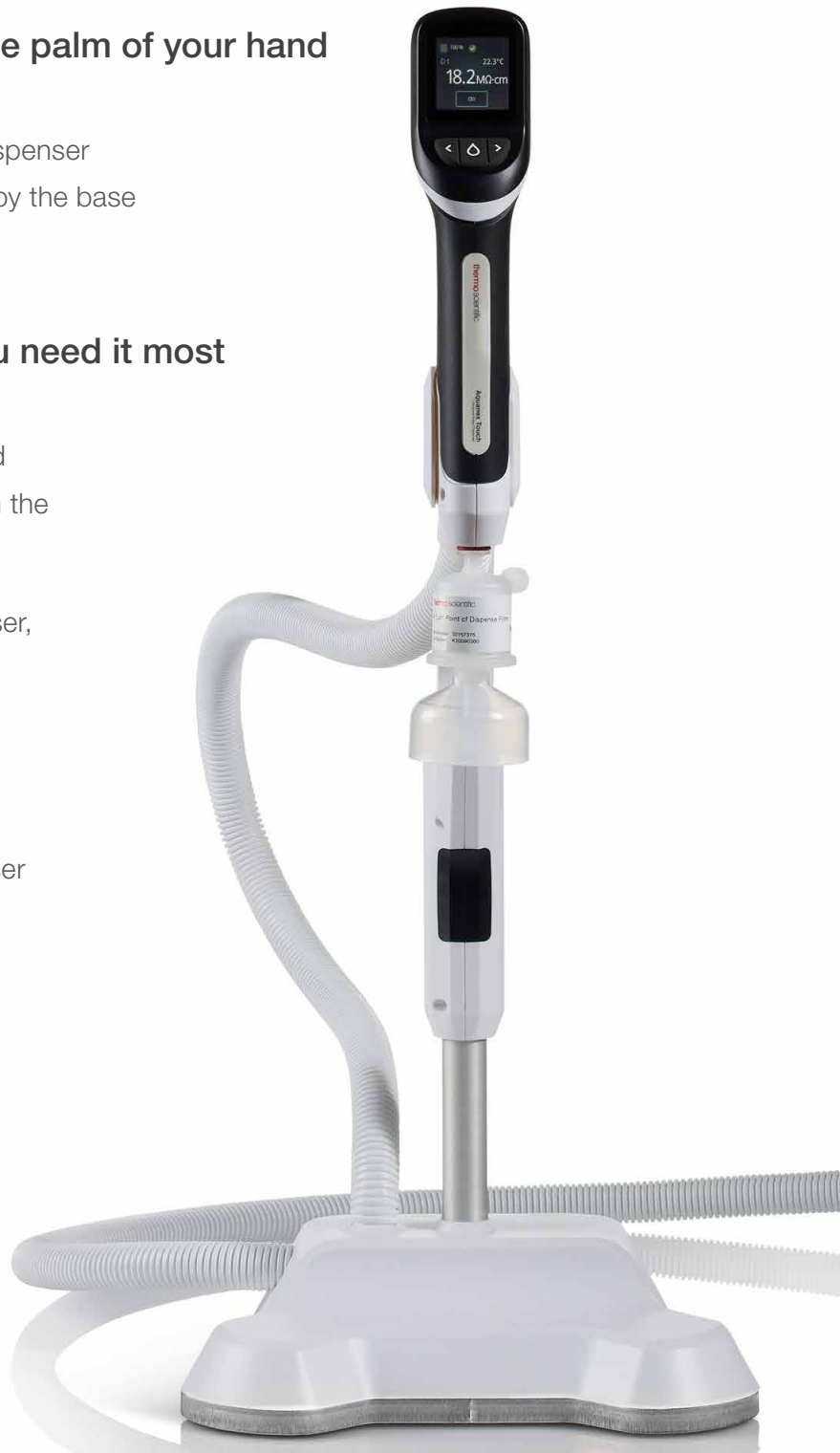

Operate with ease

View water quality, dispense type and tank fill from a distance

Easy to navigate right out of the box

The intuitive, full-color touchscreen display is easy to read and simple to operate.

- Multilanguage system accommodates user preferences to help avoid errors
- The large display allows you to clearly view water quality, type and tank fill from a distance
- View history of alerts, alarms and event and dispense logs for greater security and reproducibility
- Tap the display to set, run and monitor vital system conditions

Aquanex Touch Smart Dispenser



1. Tank level
2. Dispenser ID
3. Dispense volume setting—touchscreen
4. System health status indicator
5. Type 1 water temperature
6. Dispensing water purity
7. Dispense and flow speed selector buttons

Aquanex main unit



1. System health/status indicator
2. Unit name, time and date
3. Home screen navigation bar
4. Dispenser volume setting
5. Dispensing water purity
6. Type 1 water temperature
7. Tank level
8. Water type selector
9. Secure mode log in/out

Straightforward access to consumables

Easy maintenance and self-service design



Easily access consumables

- The Aquanex system provides step-by-step instructions on how to access and change consumables
- UV lamp, RO assembly, and ultrafilter consumables are easily accessed by removing the magnetic front panel
- No complicated tools are required to change consumables



Auto-detection and event logging

- Aquanex system automatically detects and logs when the DI cartridges are replaced
- The system will notify you when consumables are nearing the end of their life and require replacement
- Consumable installation and replacement dates can be easily viewed in the maintenance menu



Simplified DI cartridge installation

- No water spills or mess during cartridge installation or removal
- Eject DI cartridge by simply pressing a button on the side of the system
- Guide rails, built-in sensors, and a quick-connect system allow for smooth installation of DI cartridges

Water quality you can depend on

Delivering better accuracy and reproducibility

The Aquanex system offers two-point calibration for improved accuracy of volumetric dispenses, and automatically adjusts water flow for low volumes to reduce splashing. With a maximum flow rate greater than 1.5 L/min from the Aquanex Touch Smart Dispenser, and a standard leak detection sensor inside the Aquanex main unit (10 L system) or 30 L tank (30 L system), the Aquanex system is designed to meet your water purification needs.

The easily accessible user interface caters to your needs for secure access, eliminating non-authorized changes to system settings. Use secure mode to protect your water quality data by creating password-protected admin and user-level accounts for reliable data tracking. Users can also export event logs via USB in either CSV or Adobe™ PDF* formats to match your data logging requirements.



ASTM Type I water quality

(from Aquanex Touch Smart Dispenser with 0.1 POU final filter)

Parameters	Values (UV/UF)
Conductivity (reference temperature +25°C)	0.055 µS/cm
Resistance (reference temperature +25°C)	18.2 MΩ-cm
Total organic carbon (TOC)	<3 ppb
RNase	1 pg/mL
DNase	5 pg/mL
Bacteria	0.001 CFU/mL
Bacterial endotoxins	0.001 EU/mL
Particle	99.9% reduction > 0.1 µm
Dispense rate	10 L systems ≥2.0 L/min 30 L systems ≥1.5 L/min

ASTM Type II water quality

(tank quality)

Parameters	Values (UV/UF)
Conductivity (reference temperature +25°C)	0.1 to 1.0 µS/cm
Resistance (reference temperature +25°C)	1 to 10 MΩ-cm
Retention rate for bacteria and particles	99%
RO assembly permeate flow	16 ± 20% L/hr

*Adobe™ PDF is either a registered trademark or trademark of Adobe in the United States and/or other countries.

Waste less water

Customize your water usage

Select **Water Saver**, **Pack Saver** or **Dynamic Mode** for your lab operation.

- **Water Saver Mode**

Instead of sending excess water to waste while filling the tank, this mode recirculates water through the system to produce the most purified water from input water. Using the Water Saver Mode can save up to 50% more water than a typical RO operating mode, but it will impact cartridge life since the system repeatedly filters the water.

- **Pack Saver Mode**

Enhance the life of your DI cartridges and other consumables. This mode does not recirculate RO wastewater through the RO assembly, which will help lengthen the life expectancy of your cartridges and consumables. This mode can help minimize operational costs in the lab.

- **Dynamic Mode**

Let the Aquanex system intelligently choose between Pack Saver and Water Saver Modes based on your local water quality. This mode provides an optimal ratio of water saving to operational cost benefits.

Type I water operation

Type I water is the default setting for the Aquanex system and dispensed solely through the Aquanex Touch Smart Dispenser. Easily modify your reported water quality from resistivity to conductivity from the touchscreen UI. When the system comes out of sleep mode, a timer will appear to allow water purity to stabilize before you dispense, protecting the lab applications from low-quality water.



Type II water operation

Confidently switch to Type II water dispense mode from the home screen toggle when you have a hand dispenser accessory attached to the system. Use the Advanced Type II Mode (ATM) when dispensing Type II water to produce total organic carbon (TOC)-reduced Type II water for your analytical applications. To protect your system, tank filling is automatically paused when the system is in Type II mode.

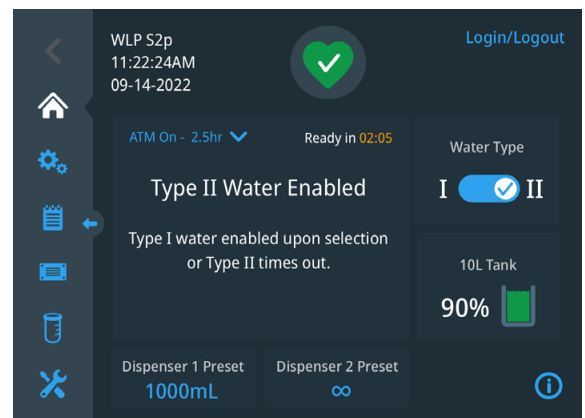

Unparalleled reliability

Designed to fit your applications

Laboratory scientists count on the consistent performance of Type I water. The intelligent Aquanex system provides reliable performance to meet the purification needs of a range of industries.

ANALYTICAL SCIENCES



Chromatography



Spectroscopy



Total organic carbon
(TOC) analysis

LIFE SCIENCES



Genomics and cell/tissue culture



Proteomics and immunology



Pharmacology and drug discovery



Molecular biology and microbiology

Technical specifications

Feed water requirements

Parameter	Description
Source	Potable tap water
Silt density index (SDI)	<3
Turbidity*	<1 NTU
Conductivity (reference temperature +25°C)	Up to 1500 µS/cm (670 Ω·cm)
Hardness*	Hardness stabilized
Chlorine*	Max. 0.1 ppm
pH range	4 to 11
Temperature	+2°C to +35°C
Pressure*	2 to 6 bar/29 to 87 PSI**

*Use of Thermo Scientific™ Barnstead™ Pretreatment System (50157886) ensures feedwater meets these requirements

**At pressure > 6 bar/87 PSI, install a pressure reducer upstream of the system

Materials in contact with ultrapure water

Consumable	Material in contact
Pump head	Nylon with glass fiber
UV lamp	High-purity synthetic quartz
UV housing	Stainless steel
DI cartridges	Polypropylene housing
UF filter	PES (polyethersulfone)
Conductivity measuring cell	POM (polyoxymethylene), stainless steel
Dispensing valve	PET (polyethylene terephthalate)
Distributor block	POM
Connections	POM
Tubing	PE (polyethylene)
O-rings	EPDM (ethylene propylene diene rubber)
Solenoids	Stainless steel

Electrical connections

Parameters	Values
Power adapter AC input voltage	AC 100 to 240 VAC, 50 to 60 Hz
Amps	Max 5.0 Amps
Watts	120 W
User interface	2 USB Type A, 1 USB Type B, Ethernet
Potential free contact	Maximum 30 V, 2 Amps
Protection class	Class II (external SMPS certified as Class I)

Aquanex main unit dimensions

Parameter	Value
Height	62.2 cm/24.5 in.
Width	61.0 cm/24.0 in.
Depth	40.6 cm/16.0 in.
Dry weight (without Aquanex DI cartridges)	32 kg/70 lb.
Wet weight (with Aquanex DI cartridges)	57 g/125 lb.
Height with CO ₂ absorber and sterile filter	73.7 cm/29 in
30 L dry weight (without Aquanex DI cartridges)	31 kg/68 lb.
30 L wet weight (without Aquanex DI cartridges)	46 kg/101 lb.

Note: A minimum of 25.0 cm (10 in.) clearance is needed above the tank



Aquanex Touch Smart Dispenser dimensions

Parameter	Value
Height	88.2 cm/34.7 in.
Width	27.1 cm/10.7 in
Depth	38 cm/15 in.
Weight	9 kg/20 lb.



Aquanex 30 L tank dimensions

Parameter	Value
Height	60.6 cm/23.9 in.
Width	38.8 cm/15.3 in.
Depth	38.4 cm/15.1 in.
Weight with full capacity	38 kg/83 lb.
Height with CO ₂ adsorber and sterile filter	77.8 cm/30.6 in.

Note: A minimum of 25.0 cm (10 in.) clearance is needed above the tank



Ordering tables

Aquanex 10 L systems

Description	Item no.
Thermo Scientific™ Aquanex™ with 10 L internal tank, Thermo Scientific™ Aquanex™ Touch Smart Dispenser with stand, Thermo Scientific™ Aquanex™ DI Cartridge Set, UV/UF, 0.1 µm final filter	7101010
Thermo Scientific Aquanex with 10 L internal tank, Aquanex Touch Smart Dispenser with stand, Aquanex DI Cartridge Set, UV/UF, 0.1 µm final filter, Thermo Scientific™ Barnstead™ Pretreatment for Point of Use (POU) Water Purification Systems	7101011

Aquanex 30 L systems

Description	Item no.
Thermo Scientific Aquanex, Aquanex Touch Smart Dispenser with stand, 30 L external tank, Aquanex DI Cartridge Set, UV/UF filter, and 0.1 µm final filter	7201030
Thermo Scientific Aquanex, Aquanex Touch Smart Dispenser with stand, 30 L external tank, Aquanex DI Cartridge Set, UV/UF filter, 0.1 µm final filter, and Barnstead Pretreatment System	7201031

Consumables

Description	Item no.
Thermo Scientific™ Aquanex™ DI Cartridge Set, includes one right (A) and one left (B) cartridge [§]	7501050
Thermo Scientific™ Barnstead™ POU Water Purification Systems Replacement UV Lamps ^{††}	09.2002
Thermo Scientific™ Barnstead™ POU Water Purification Systems Ultrafilters for pyrogens and nucleases ^{††}	50133980
Thermo Scientific™ Barnstead™ POU 0.1 µm Final Filter Membrane [‡]	50157375
Thermo Scientific™ Reverse Osmosis Cartridge [§]	50157608
Thermo Scientific™ CO ₂ Adsorber and Sterile Filter [§]	06.5002
Thermo Scientific™ Barnstead™ Pretreatment 1 µm Prefilter [‡]	D502113
Thermo Scientific™ Barnstead™ Pretreatment MPS Cartridge [‡]	D502114
Thermo Scientific™ Barnstead™ Pretreatment Carbon Cartridge [‡]	D502115

[‡]Estimated consumable lifetime up to 6 months

[§]Estimated consumable lifetime up to 12 months

^{††}Estimated consumable lifetime up to 24 months

Accessories

Description	Item no.
Touch Smart Dispenser and Stand for Aquanex	7601040
Type II Hand Dispenser Kit for Aquanex	50138221
Wall Mount for Aquanex	7601060
Sterile Overflow Tank for 30 L Aquanex Tank	06.5001
Thermo Scientific™ Barnstead™ Pretreatment for POU Water Purification Systems, includes pre-filter, hardness stabilizer and carbon filter [‡]	50157886

[‡]Estimated consumable lifetime up to 6 months



Flow diagram

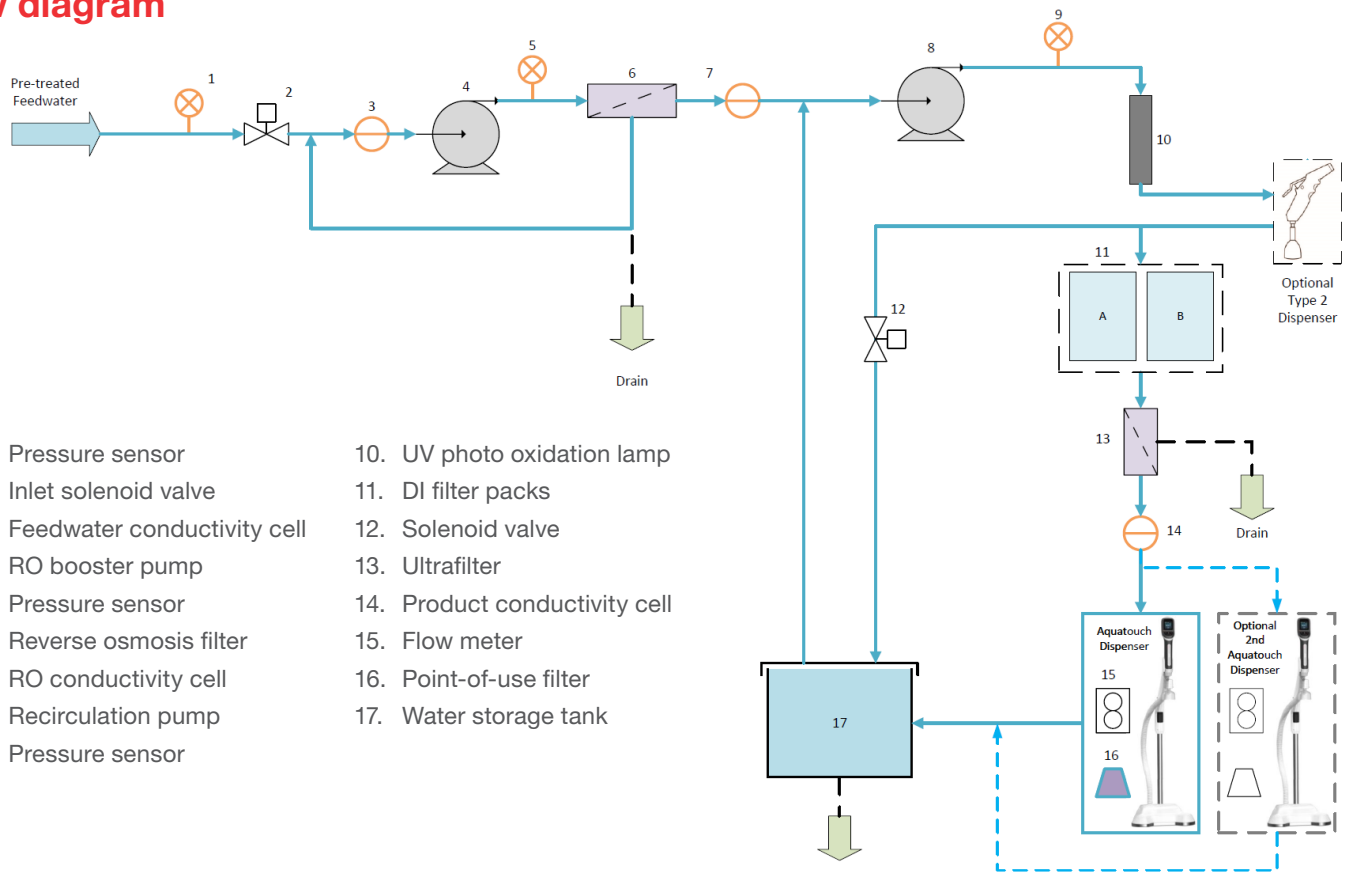

- | | |
|--------------------------------|-------------------------------|
| 1. Pressure sensor | 10. UV photo oxidation lamp |
| 2. Inlet solenoid valve | 11. DI filter packs |
| 3. Feedwater conductivity cell | 12. Solenoid valve |
| 4. RO booster pump | 13. Ultrafilter |
| 5. Pressure sensor | 14. Product conductivity cell |
| 6. Reverse osmosis filter | 15. Flow meter |
| 7. RO conductivity cell | 16. Point-of-use filter |
| 8. Recirculation pump | 17. Water storage tank |
| 9. Pressure sensor | |

Learn more at www.canadawide.ca

For Laboratory Use. It is the customer's responsibility to ensure that the performance of the product is suitable for customers' specific uses or applications.

© 2019–2023 Thermo Fisher Scientific Inc. All rights reserved. All trademarks are the property of Thermo Fisher Scientific and its subsidiaries unless otherwise specified. **EXT6101**

23-892-1946 TL 08/23 BN236286106-NA